

MANHOLE PRODUCTION

PERFECT BASE
EXACT 1500
MAGIC 1501
MAGIC 2500
PRECISE
RINGMASTER





PERFECT Base LEAKPROOF

The quality standard in manhole construction.

PERFECT concrete manhole bases for storm drain and sewage monobases are individually customized according to project requirements. Manufactured in industrial scale, PERFECT concrete manhole bases are available within less than 24 hours in a unique monolithic quality.

Range of Products

- Custom made: the number and diameter as well as inclination and angle of required pipe connections, as well as the height of the inlets, can be individually adapted.
- Monolithic-produced in one pour. Consistently defined reproducible concrete quality (SCC-self-compacting concrete) throughout the product-berm, bottom, wall-and outstanding surface quality without finishing.
- Connections of all types of pipe available: concrete, reinforced concrete, vitrified clay, PVC, PEHD, PUR, cast iron, etc.

Plant Concept

- PERFECT production system as a combination of high-quality mould equipment and our state-of-the-art hot wire cutting technology for true-to-size moulded parts. PERFECT production system can be automated in steps: from manual product manipulation through to fully automated plant incl. TRANSEXACT or high-rack curing zone.
- PERFECT production system including management of all planning and logistics procedures. Starting with the comprehensive registration of all product data and work scheduling, through to the production, storage and customized product marking; all production steps are integrated into one system.

Performance Profile

- High-quality, industrially manufactured concrete manhole bases, available in a variety of concrete qualities
- Focus of production capacity can be adapted to customer's individual requirements, multi-shift operation is possible
- Economical assignment of resources by means of reduced material costs and optimized personnel expenses

Product parameters

Nominal diameter

from 24 up to 83 inches
(600-2100 mm)

Pipe connections

from 4 up to 40 inches (1000 mm)

Wall thickness

from 4 up to 17 inches
(100-420 mm)

Individually determined

- Number of connections
- Connection angle
- Heights (channel, connections, overall height)
- Inclination of the channel
- Inclination of the berm



Full Design Liberty

- Manufacturing of customized manhole bases
- All components including special project-specific elements can be planned and produced using one production system.

Visible Quality

PERFECT EPS moulded parts provide smooth concrete surfaces, without the need for finishing work on the channel body shape and concrete channel.

Leakproof, Right Down to the Pipe Connection

PERFECT manhole bases are reliably leakproof, thanks to the selective use of SCC and integrated gaskets firmly attached to the concrete.

Fast and Secure Installation

- User-friendly manufacturing process for customized negative channels
- High monobase manufacturing productivity right from the start, with an average of 12 complete EPS negative channels produced per worker per hour
- Simple and quick demoulding and recycling of the EPS moulded parts: The recycled material can easily be reused for numerous industrial purposes.
- Optimized consumption of material due to usage of EPS moulded parts with low moulded part volumes for all manhole bases of all nominal diameters.

Economical components for long-lasting sewage systems



EXACT 1500



Modular, fully automated production system for manhole risers with high dimensional accuracy

Product parameters

up to Ø 72 inches (1800 mm) or up to 50 x 50 inches (1270 x 1270 mm) external dimension, single production

up to 48 inches (1200 mm) building height

up to 5000 lbs. (2300 kg) product weight

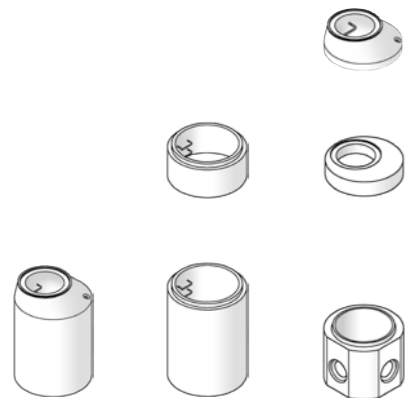

Range of Products

- Manhole risers and manhole cones
- Pipe connection pieces
- Non-circular diameter concrete products
- Other products upon request

Plant Concept

- EXACT 1500** as sole production machine, with manual product transport
- EXACT 1500** as fully automatic production system. Including production, transport and storage of the products, as well as cleaning, oiling and the manipulation of the headers and pallets

Performance Profile

- Precision spigot ends thanks to EXACT header system
- Mould-quick-change system enables short change-over times
- High-quality immediately demoulded manhole components
- Minimum staff requirements (one-man operation possible)

MAGIC 1501 MAGIC 2500



Production system for manhole components such as rings and cones, as well as for road drain parts and slip tubes in large quantities



Product parameters MAGIC 1501

up to Ø 32 inches (820 mm) external dimension, double production

up to Ø 72 inches (1800mm) or up to 50 x 50 inches (1270 x 1270 mm) external dimension, single production

up to 5 ft. (1500 mm) building height

up to 5500 lbs. (2500 kg) product weight

Product parameters MAGIC 2500

up to Ø 106 inches (2700 mm) or up to 75 x 75 inches (1900 x 1900 mm) external dimension, single production

up to 40 inches (1000 mm) building height

up to 6600 lbs. (3000 kg) product weight

Range of Products

- Manhole risers and manhole cones
- Sewage rings and chamber rings
- Rectangular manholes
- Pipe connection pieces
- Other products upon request

Plant Concept

- MAGIC** as sole production machine, with manual product transport
- MAGIC** as fully automatic production system. Including production, transport and storage of the products, as well as cleaning, oiling and the manipulation of the pallets

Performance Profile

- Single and multiple production possible
- One-man operation possible
- Mould-quick-change system enables short change-over times
- Modular plant concept

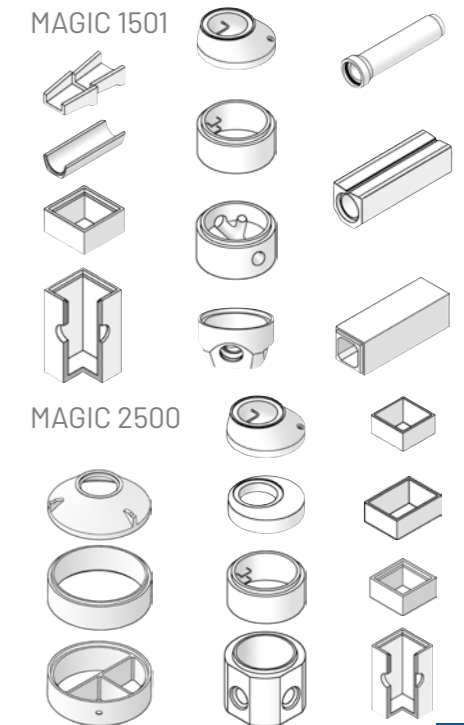

PRECISE



Production system for manhole components as well as reinforced and non-reinforced concrete pipe, road side channels, and pipe connection parts

Product parameters
up to Ø 32 inches (820 mm) external dimension, double production
up to Ø 72 inches (1800 mm) or up to 50 x 50 inches (1270 x 1270 mm) external dimension, single production
up to 8 ft. (2500 mm) building height
up to 8500 lbs. (3900 kg) product weight

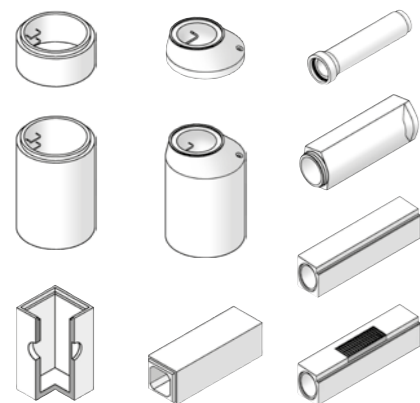

Range of Products

- Manhole components (manhole risers, cones, pipes)
- Reinforced and non-reinforced pipe in single or double production
- Pipe connection pieces
- Non-circular diameter concrete products
- Road side channels
- Other products upon request

Plant Concept

- PRECISE** as sole production machine, with manual product transport
- PRECISE** as fully automatic production system. Including production, transport and storage of the products, as well as cleaning, oiling and the manipulation of the pallets

Performance Profile

- Single and twin production possible
- Mould-quick-change system enables short change-over times
- Top quality of the produced components

RING-MASTER



For reinforced or non-reinforced, round or square concrete products



Range of Products

- Adjustment rings with and without rebated joint
- Covers, cover plates, frame sections
- Road side channels, drainage products
- Small format manhole risers
- Non-circular diameter concrete products
- Other products upon request

Plant Concept

- RINGMASTER** as an autonomous machine with primarily manual handling and product transport with electrical cart for transportation
- RINGMASTER** with semi-automatic handling. With product ejector and electric cart for transportation
- RINGMASTER** as a fully automatic production system, covering all processes up to packaging of the products with minimal work input

Performance Profile

- Production without bottom pallets possible, which enables a very efficient packaging of the products already during production; no bottom pallet management required.
- Production of covers, plates and difficult concrete elements with bottom pallets
- RINGMASTER** requires no machine pit, and is therefore quickly assembled and put into operation.
- Fast and simple mould exchange possible
- Simple, one-man operation

Product parameters
up to Ø 43 inches (1100 mm) or up to 31 x 31 inches (780 x 780 mm) external dimension, single production
up to 12 inches (300 mm) building height
up to 550 lbs. (250 kg) product weight

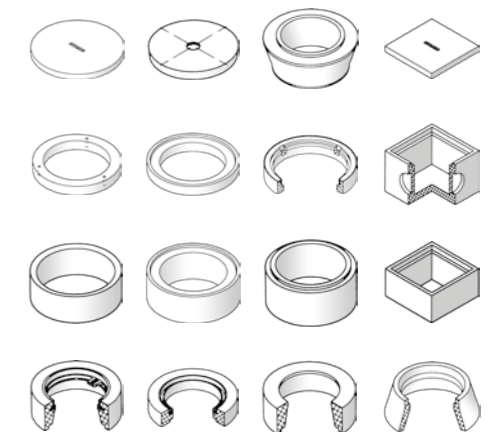



SCHLÜSSELBAUER 
TECHNOLOGY

SCHLÜSSELBAUER Technology GmbH & Co. KG
Hörbach 4, 4673 Gaspoltshofen, Austria
Tel. +43 7735 7144-0
E-mail: sbm@sbm.at | www.sbm.at

SCHLÜSSELBAUER NORTH AMERICA LLC
104 Hartmann Commerce Drive, Lebanon, TN 37090, USA
Tel. +1 615 742 7274
E-mail: support@sbt-na.com | www.sbt-na.com